

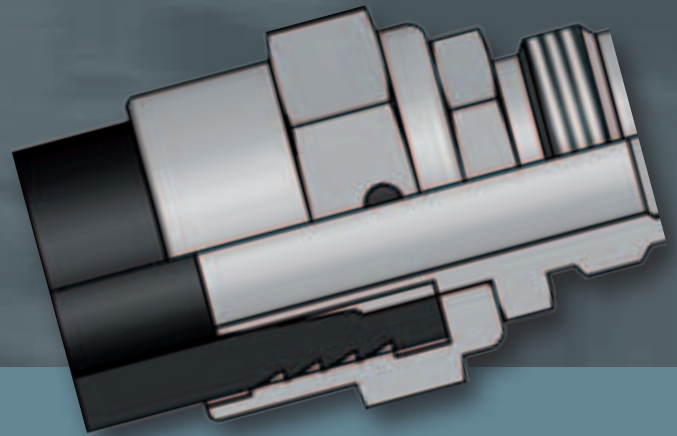

Complete Screwing Sets are extremely robust fittings for construction, tunneling and mining. A tapered stem with connecting nut is screwed with a nipple with cone. Taper and cone are sealing against each other without sealing material.

Thread stems and hose connections serve in various fields for connection or lengthening of hose lines.

Complete Screwing Sets Connecting Nipples Hose Connections



Content

- 37 Complete Screwing Sets DIN 8537/20 033
- 39 Complete Screwing Sets, flat sealing
- 40 Connecting Nuts and Tapered Stems DIN 8537/20 033
- 42 Connecting Nipples with Cone, Hot Tar Screwing
- 44 Thread Stems
- 45 Hose Connections

LÜDECKE

Since 1930. The perfect connection.

Our sales team is at your disposal as the competent contact: Phone +49 9621 7682-0 or eMail: info@luedecke.de

Complete Screwing Sets

DIN 8537/20 033

New!

- Complete Screwing Sets of malleable iron / steel, zinc plated and yellow passivated (free of chrome VI) consisting of connecting nut and tapered stem
- Complete Screwing Sets with safety collar and turned stem profile for perfect fit of the hose
- Tapered stems with cone 1:3 generally with additional O-ring sealing
- Suitable for connecting nipples (© catalogue page 42 / 43)
- World-wide used system for compressed air, water... in construction, mining or tunneling.

Max. Working Pressure	Temperature	Material	Medium	Norm	Thread	Cone
PN 16 / 25 bar	- 40°C – + 95°C	malleable iron / steel	compressed air / water	DIN 8537 / 20 033	ISO 228 / DIN 405	1:3 resp. 1:4

Complete Screwing Sets with safety collar

Hose i.D.	Thread	Cone	DN	Ø Safety collar	b	h	Weight/pc. g	⊠	Type No.
3/8" = 10 mm	G 3/4"	1:4	7.5	21	58	70	169	10	34/10 S
1/2" = 13 mm	G 3/4"	1:4	10	21	58	79	166	10	34/13 S
5/8" = 15 mm	G 3/4"	1:4	12	26	58	79	175	10	34/15 S
3/4" = 19 mm	G 3/4"	1:4	13	33	58	80	200	10	34/19 S
3/8" = 10 mm	G 1"	1:3	7.5	21	65	83	218	10	10/10 S
1/2" = 13 mm	G 1"	1:3	10	22	65	85	207	10	10/13 S
5/8" = 15 mm	G 1"	1:3	12	26	65	85	218	10	10/15 S
3/4" = 19 mm	G 1"	1:3	15	33	65	85	244	10	10/19 S
1" = 25 mm	G 1"	1:3	16	38	65	90	290	10	10/25 S
3/8" = 10 mm	Rd 32 x 1/8"	1:3	7.5	21	65	90	221	10	32/10 S
1/2" = 13 mm	Rd 32 x 1/8"	1:3	10	22	65	83	249	10	32/13 S
5/8" = 15 mm	Rd 32 x 1/8"	1:3	12	26	65	85	229	10	32/15 S
3/4" = 19 mm	Rd 32 x 1/8"	1:3	15	33	65	85	251	10	32/19 S
1" = 25 mm	Rd 32 x 1/8"	1:3	16	38	65	90	310	10	32/25 S
1" = 25 mm	Rd 38 x 1/8"	1:3	19	38	76	98	426	5	38/25 S
1 1/4" = 32 mm	Rd 46 x 1/6"	1:3	25	50	86	124	685	1	46/32 S
1 3/8" = 35 mm	Rd 55 x 1/6"	1:3	30	55	95	131	829	1	55/35 S
1 1/2" = 38 mm	Rd 55 x 1/6"	1:3	31	55	95	131	864	1	55/38 S
1 5/8" = 42 mm	Rd 62 x 1/6"	1:3	35	63	105	139	1216	1	62/42 S
1 1/2" = 38 mm	Rd 75 x 1/6"	1:3	31	55	137	140	1420	1	75/38 S
2" = 50 mm	Rd 75 x 1/6"	1:3	45	77	137	149	1725	1	75/50 S
2" = 53 mm	Rd 75 x 1/6"	1:3	45	77	137	149	1848	1	75/53 S
3" = 75 mm	Rd 105 x 1/4"	1:3	67	110	158	206	3974	1	105/75 S

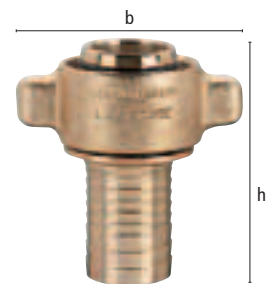

For hose clamps DIN 20039 B, type SK (© catalogue page 47)

For higher temperatures we recommend steam screwings DIN EN 14 423 (© catalogue page 72)

Flat Hose Fittings (on request)

New!

We produce flat hose fittings according to hose samples/dimensions with assembly recommendation for hydraulic crimping with crimping sockets, safety clamps, wire or steel band. Various types on stock!



Complete Screwing Sets

DIN 8537/20 033 with male thread

New!

New!

- Screwings with cone made of steel/malleable iron, zinc plated and yellow passivated (free of chrome VI), consisting of connecting nut and tapered nipple
- Complete Screwing Set for the direct connection of thread to machine/tool
- Tapered nipple with cone 1:3 generally with additional O-ring sealing
- World-wide used system for compressed air in construction, mining and tunnelling

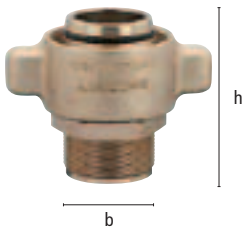

Max. Working Pressure	Temperature	Material	Medium	Norm	Thread	Cone	⊗
PN 16 / 25 bar	- 40°C – + 95°C	steel / malleable iron	compressed air	DIN 8537 / 20 033	ISO 228 / DIN 405	1:3	1

Complete Screwing Sets with male thread

Male thread	Female thread	Cone	DN	⊞Hexagon	b	h	Weight/pc. g	Type No.
connecting nut								
G 1 1/4"	Rd 55 x 1/6"	1:3	32	50	95	87	890	55/54 A
G 2"	Rd 75 x 1/6"	1:3	45	65	137	115	1850	75/20 A

Other dimensions on request.

Screw Caps for Complete Screwing Sets DIN 8537 / 20 033

Thread	Cone	h	⊞Hexagon	Weight/pc. g	⊞	Type No.
Rd 75 x 1/6"	1:3	65	75	850	5	VS 75

With hexagon to facilitate the assembly.

Other dimensions on request.

Male thread stems with cone

Hose i.D.	Thread	Cone	DN	h	⊞Hex.	Stem l.	Weight/pc. g	⊞	Type No.
1/2" = 13 mm	Rd 32 x 1/8"	1:3	10	75	32	41	150	10	G 32-13 T
5/8" = 16 mm	Rd 32 x 1/8"	1:3	13	75	32	41	154	10	G 32-16 T
3/4" = 19 mm	Rd 32 x 1/8"	1:3	15	75	32	41	156	10	G 32-19 T
1" = 25 mm	Rd 32 x 1/8"	1:3	20	75	32	41	168	10	G 32-25 T
1" = 25 mm	Rd 38 x 1/8"	1:3	20	75	41	41	210	10	G 38-25 T
1 1/2" = 38 mm	Rd 55 x 1/6"	1:3	33	95	55	50	800	1	G 55-38 T*
2" = 50 mm	Rd 75 x 1/6"	1:3	45	117	75	65	1120	1	G 75-50 T*
2" = 53 mm	Rd 75 x 1/6"	1:3	47	117	75	65	1140	1	G 75-53 T*

Suitable for Complete Screwing Sets.

For hose clamps DIN 20039 A, type SL (⊗ catalogue page 47)

Further dimensions on request.

*with safety collar, other types without safety collar

New!

Complete Screwing Sets flat sealing

New!

- Screwings made of steel/malleable iron, zinc plated and yellow passivated (free of chrome VI)
- Consisting of connecting nut and flat sealing hose stem with O-ring
- Complete Screwing Sets with turned stem profile for perfect fit of the hose
- Further hose assembly methods, for example with crimping sockets or safety clamps, and also other dimensions on request
- Popular screwing system for compressed air in mining and tunnelling

Max. Working Pressure	Temperature	Material	Medium	Thread	
PN 16 / 25 bar	- 40°C – + 95°C	malleable iron/steel	compressed air	DIN 405	1

Complete Screwing Sets with safety collar, flat sealing

Hose i.D.	Thread	DN	h	b	Weight/pc. g	Type No.
2" = 50 mm	RD 65 x 1/6"	45	166	105	1300	65/50 FL
2" = 53 mm	RD 65 x 1/6"	47	166	105	1320	65/53 FL

For hose clamps DIN 20 039 A, type SL (☺ catalogue page 47)

Single Connecting Nuts

Thread	Bore	h	b	Weight/pc. g	Type No.
Rd 65 x 1/6"	56,5	36	105	555	UM 65

Single Hose stems, flat sealing

Hose i.D.	DN	h	Weight/pc. g	Type No.
2" = 50 mm	45	166	745	FT 50 L
2" = 53 mm	48	166	765	FT 53 L

For hose clamps DIN 20 039 A, type SL (☺ catalogue page 47)

Rubber rings for flat sealing hose stems

Resistance	Temp. °C	Medium	Material	Shore h. A	∅A	Weight/pc. g	Type No.
Oil	-40°C - +95°C	compressed air	Perbunan	65 °	54,5	2	ED 50 L

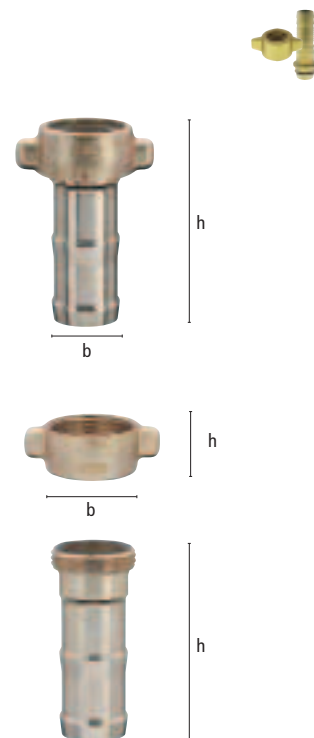

New!

Double Nipples flat sealing

New!

- Nipples made of steel, zinc plated and yellow passivated (free of chrome VI)
- Suitable for flat sealing Complete Screwings(☺ above)
- For the direct connection of fitting to machine/tool for compressed air in mining and tunnelling

Max. Working Pressure	Temperature	Material	Medium	Thread	
PN 25 bar	- 40°C – + 95°C	steel	compressed air	ISO 228 / DIN 405	1

Double nipples, flat sealing, male/male resp. male/female

Inlet thread	outlet thread	∅Hexagon	h	Weight/pc. g	Type No.
G 1 1/4" male	RD 65 x 1/6" male	65	58	665	N 6554 A
G 1 1/2" male	RD 65 x 1/6" male	65	58	675	N 6515 A
G 2" male	RD 65 x 1/6" male	65	58	680	N 6520 A
G 2" female	RD 65 x 1/6" male	65	55	650	N 6520 I
RD 75 x 1/6" male	RD 65 x 1/6" male	75	77	1192	N 6575 A

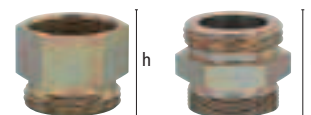

Connecting Nuts and Tapered Stems

DIN 8537/20 033

New!

- Screwings with cone of malleable iron / steel, zinc plated and yellow passivated (free of chrome VI), consisting of connecting nut and tapered stem
- Turned stem profile for perfect fit of the hose
- Tapered stems with cone 1:3 generally with additional O-ring sealing
- Suitable for connecting nipples (© catalogue page 42 / 43)
- World-wide used system for compressed air, water... in construction, mining or tunneling.

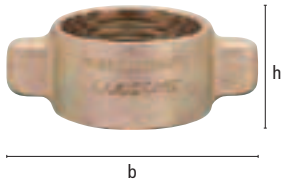

Connecting Nuts of malleable iron corresponding to →

Thread	Bore	b	h	Weight/pc. g		Type No.
G 3/4"	21.5	58	23	92	10	UM 34
G 3/4"						
G 3/4"						
G 3/4"						
G 1"	23	65	28	133	10	UM 10
G 1"						
G 1"						
G 1"						
G 1"						
Rd 32 x 1/8"	23	65	28	139	10	UM 32
Rd 32 x 1/8"						
Rd 32 x 1/8"						
Rd 32 x 1/8"						
Rd 32 x 1/8"						
Rd 32 x 1/8"						
Rd 32 x 1/8"	27.5	65	28	129	10	UM 32/2
G1"	27.5	65	28	124	10	UM 10/2
Rd 38 x 1/8"	29	76	33	234	10	UM 38
Rd 46 x 1/6"	35	86	36	301	1	UM 46
Rd 55 x 1/6"	42	95	38	378	1	UM 55
Rd 55 x 1/6"						
Rd 62 x 1/6"	49	105	44	555	1	UM 62
Rd 75 x 1/6"	61	137	50	797	1	UM 75
Rd 75 x 1/6"						
Rd 105 x 1/4"		158	60	1545	1	UM 105



tapered stems of steel

Hose i.D.	Cone	b	h	Weight/pc. g		Type No.
3/8" = 10 mm	1:4	24	70	67	10	T 10 B
1/2" = 13 mm	1:4	24	79	74	10	T 13 B
5/8" = 15 mm	1:4	24	79	72	10	T 15 B
3/4" = 19 mm	1:4	24	80	94	10	T 19 B
3/8" = 10 mm	1:3	28	78	85	10	ST 10 B
1/2" = 13 mm	1:3	28	80	104	10	ST 13 B
5/8" = 15 mm	1:3	28	80	83	10	ST 15 B
3/4" = 19 mm	1:3	28	80	100	10	ST 19 B
3/4" = 19 mm	1:3	28	80	109	10	ST 19 B-PH*
3/8" = 10 mm	1:3	28	78	85	10	ST 10 B
1/2" = 13 mm	1:3	28	80	104	10	ST 13 B
5/8" = 15 mm	1:3	28	80	83	10	ST 15 B
3/4" = 19 mm	1:3	28	80	100	10	ST 19 B
3/4" = 19 mm	1:3	28	80	109	10	ST 19 B-PH*
1" = 25 mm	1:3	29	85	163	10	ST 25 B/3
1" = 25 mm	1:3	30	85	148	10	ST 25 B/2
1" = 25 mm	1:3	33	90	164	10	ST 25 B
1 1/4" = 32 mm	1:3	40	120	355	1	ST 32 B
1 3/8" = 35 mm	1:3	48	125	390	1	ST 35 B
1 1/2" = 38 mm	1:3	48	125	465	1	ST 38 B
1 5/8" = 42 mm	1:3	57	130	558	1	ST 42 B
2" = 50 mm	1:3	68	140	896	1	ST 50 B
2" = 53 mm	1:3	68	140	947	1	ST 53 B
3" = 75 mm	1:3	98	189	1990	1	ST 75 B



For hose clamps DIN 20039 A, type SL (☺ catalogue page 47)

*ST 19 B-PH for hydraulic crimping with socket PH-19 (☺ catalogue page 59)
other types also available on request!

Connecting Nipples with cone

New!

- Nipples of steel, zinc plated and yellow passivated (free of chrome VI)
- Suitable for screwings (☉ catalogue page 37–41) DIN 8537/20033
- Worldwide used system for compressed air, water... in construction, mining and tunneling



Max. Working Pressure	Material	Medium	Norm	Thread	Cone
PN 25 bar	steel	compressed air / water	☉ below	ISO 228 / DIN 405	1:3 resp.1:4

Double Nipples DIN 8537/20 036

Male Thread	Cone	Hexagon	h	Weight/pc. g	Weight/pc. g	Type No.
2 x G 3/4"	2 x 1:4	27	47	107	10	V 34 N
2 x G 3/4"	2 x 1:4	32	47	125	10	V 34-32 N
2 x G 1"	2 x 1:3	36	55	197	10	V 10 N
2 x Rd 32 x 1/8"	2 x 1:3	32	55	163	10	V 32 N
2 x Rd 38 x 1/8"	2 x 1:3	41	62	283	10	V 38 N
2 x Rd 46 x 1/6"	2 x 1:3	46	70	410	1	V 46 N
2 x Rd 55 x 1/6"	2 x 1:3	55	78	648	1	V 55 N
2 x Rd 62 x 1/6"	2 x 1:3	65	88	869	1	V 62 N
2 x Rd 75 x 1/6"	2 x 1:3	75	100	1490	1	V 75 N
2 x Rd 105 x 1/4"	2 x 1:3	105	122	2990	1	V 105 N

Sieve Nipples DIN 20 037

Inlet thread	Sieve	Outlet thread	with Cone	Hexagon	h	Weight/pc. g	Weight/pc. g	Type No.
G 3/8"	inner	G 3/4"	1:4	27	38	84	10	N 38 IS
G 1/2"	inner	G 3/4"	1:4	27	40	85	10	N 23 IS
G 1/2"	inner	Rd 32 x 1/8"	1:3	32	44	126	10	N 82 IS
G 3/4"	inner	G 3/4"	1:4	27	44	104	10	N 34 IS
G 3/4"	inner	G 3/4"	1:4	32	44	120	10	N 34-32 IS
G 3/4"	inner	Rd 32 x 1/8"	1:3	32	48	135	10	N 32 IS
G 3/4"	inner	G 1"	1:3	36	48	173	10	N 341 IS
G 3/4"	outer	G 3/4"	1:4	27	44	100	10	N 34 AS
G 3/4"	outer	G 3/4"	1:4	32	44	120	10	N 34-32 AS
G 3/4"	outer	Rd 32 x 1/8"	1:3	32	48	130	10	N 32 AS
G 3/4"	without	Rd 32 x 1/8"	1:3	32	48	142	10	N 32 OS
G 1"	inner	Rd 32 x 1/8"	1:3	36	49	193	10	N 132 IS
G 1"	without	Rd 38 x 1/8"	1:3	41	54	252	10	N 18 OS
G 1"	without	Rd 46 x 1/6"	1:3	46	58	345	1	N 46-10 OS
G 1 1/4"	without	Rd 46 x 1/6"	1:3	46	58	331	1	N 46-54 OS
G 1 1/2"	without	Rd 46 x 1/6"	1:3	50	63	445	1	N 46 OS
G 1 1/4"	without	Rd 55 x 1/6"	1:3	55	63	536	1	N 55-54 OS
G 1 1/2"	without	Rd 55 x 1/6"	1:3	55	68	529	1	N 55 OS
G 2"	without	Rd 55 x 1/6"	1:3	65	70	860	1	N 55-20 OS
G 1 1/2"	without	Rd 62 x 1/6"	1:3	65	75	764	1	N 62 OS
G 2"	without	Rd 62 x 1/6"	1:3	65	75	820	1	N 62-20 OS
G 1 1/2"	without	Rd 75 x 1/6"	1:3	75	80	1220	1	N 75-15 OS
G 2"	without	Rd 75 x 1/6"	1:3	75	85	1196	1	N 75 OS
G 2 1/2"	without	Rd 75 x 1/6"	1:3	75	85	1387	1	N 75-25 OS
G 3"	without	Rd 105 x 1/4"	1:3	105	100	2290	1	N 105 OS

New!

New!

Connecting Nipples

Female thread	Male thread	with Cone	Hexagon	h	Weight/pc. g	Weight/pc. g	Type No.
G 3/4"	G 3/4"	1:4	32	44	126	10	A 34 N
G 3/4"	G 1"	1:3	36	48	200	10	A 3410 N
G 3/4"	Rd 32 x 1/8"	1:3	32	47	136	10	A 32 N
G 3/4"	Rd 38 x 1/8"	1:3	41	48	270	10	A 38 N
G 1"	Rd 32 x 1/8"	1:3	41	50	206	10	A 1032 N
G 1"	Rd 38 x 1/8"	1:3	41	52	239	10	A 10 N

Connecting Nipples with cone

Self-locking Nipple with brass valve

Connecting thread	Thread to hose with Cone	Hexagon	h	Weight/pc. g	Type No.
G 3/4"	Rd 32 x 1/8" 1:3	32	49	153	10 SN 32 ST



Combination Nipple

Thread with Cone	Thread with Cone	Hexagon	h	Weight/pc. g	Type No.
G 1" 1:3	G 3/4" 1:4	36	51	179	10 V 1034 N



Hot Tar Screwing

New!

- Hot tar screwing of steel/malleable iron, zinc plated and yellow passivated (free of chrome VI)
- Easy to screw through wing nut; tapered stem with safety collar
- For hose connection on hot tar spraying devices, hot tar lances a.o.

Max. Working Pressure	Material	Medium	Thread	Cone	Hexagon
PN 25 bar	malleable iron / steel	hot tar	ISO 228	1:3	1

Hot Tar Screwing

Type	Connection	DN	Weight/pc. g	Type No.
hot tar screwing complete	Hose i.D. 3/4" = 19 mm x G 3/4" female	15	506	HTV-SB
tapered stem	Hose i.D. 3/4" = 19 mm, Cone 1:3	15	200	HTVT-SB
wing nut	G 1 1/4" female	-	207	HTVM
nipple	G 3/4" female x G 1 1/4" male, Cone 1:3	-	99	HTVET

For hose clamps DIN 20039 B, type SK 34 (© catalogue page 47)
Other sizes on request.



Thread Stems

New!

- Thread stems of steel, zinc plated and yellow passivated (free of chrome VI)
- Turned stem profile for perfect fit of the hose
- Maximum bore for maximum flow capacity
- Suitable for compressed air and other fluids in construction, industry or plant engineering.



Max. Working Pressure	Material	Medium	Thread
PN 16 / 25 bar	steel	compressed air, a.o.	ISO 228 / DIN 405

Male thread stems without safety collar



Hose i.D.	Thread	DN	h	Hexagon	Stem Length	Thread Length	Weight/pc. g	Type No.
3/8" = 9 mm	G 1/4"	6	44	14	28	9	22	G 14-9 T
3/8" = 10 mm	G 3/8"	7	45	19	28	10	31	G 38-10 T
1/2" = 13 mm	G 1/4"	8.5	44	17	28	9	35	G 14-13 T
1/2" = 13 mm	G 3/8"	10	45	19	28	10	35	G 38-13 T
1/2" = 13 mm	G 1/2"	10	65	22	41	15	60	G 12-13 T
1/2" = 13 mm	G 3/4"	10	65	27	41	16	85	G 34-13 T
5/8" = 15 mm	G 3/8"	10	48	22	41	10	45	G 38-15 T
5/8" = 15 mm	G 1/2"	12	65	22	41	15	62	G 12-15 T
5/8" = 15 mm	G 3/4"	12	65	27	41	16	92	G 34-15 T
3/4" = 19 mm	G 1/2"	14	65	22	41	15	82	G 12-19 T
3/4" = 19 mm	G 3/4"	15	65	27	41	16	99	G 34-19 T
1" = 25 mm	G 3/4"	19	65	27	39	16	118	G 34-25 T

For hose clamps DIN 20039 A, type SL (© catalogue page 47)

Male thread stems with safety collar



Hose i.D.	Thread	DN	h	Hexag.	Stem Length	Thread Length	Safety collar	Weight/pc. g	Type No.
1/2" = 13 mm	G 1/2"	10	73	22	40	15	22	75	G 12-13 TB
3/4" = 19 mm	G 3/4"	15	72	32	40	15	32	142	G 34-19 TB
3/4" = 19 mm	G 1"	15	74	36	40	17	32	175	G 10-19 T
1" = 25 mm	G 1"	20	80	36	41	17	36	220	G 10-25 T
1" = 25 mm	G 1 1/4"	20	90	46	48	18	39	321	G 54-25 T
1 1/4" = 32 mm	G 1 1/4"	25	92	46	48	20	45	406	G 54-32 T
1 1/2" = 38 mm	G 1 1/2"	33	100	55	51	22	53	532	G 15-38 T
1 5/8" = 42 mm	G 1 1/2"	35	100	55	51	22	54	571	G 15-42 T
2" = 50 mm	G 2"	42	125	65	72	25	64	943	G 20-50 T
2" = 53 mm	G 2"	44	125	75	72	25	74	1123	G 20-53 T
3" = 75 mm	G 3"	68	185	90	120	30	95	2033	G 30-75 T

For hose clamps DIN 20039 B, type SK (© catalogue page 47)

Female thread stems with safety collar



Hose i.D.	Thread	DN	h	Hexag.	Stem Length	Thread Length	Safety collar	Weight/pc. g	Type No.
3/4" = 19 mm	G 3/4"	15	71	32	40	19	32	134	G 34-19 TI
3/4" = 19 mm	G 1"	15	73	41	40	20	32	197	G 10-19 TI
1" = 25 mm	G 1"	20	75	41	41	20	36	227	G 10-25 TI
1" = 25 mm	G 1 1/4"	20	80	50	41	23	36	323	G 54-25 TI
1 1/4" = 32 mm	G 1 1/4"	25	86	50	48	23	45	390	G 54-32 TI

For hose clamps DIN 20039 B, type SK (© catalogue page 47)

Hose Connections

New!

- Hose menders and -grips of steel, zinc plated and yellow passivated (free of chrome VI)
- Simple and safe hose connection with turned stem profile
- Male thread nipples with thread ferrule reusable!
- Maximum bore for maximum flow capacity
- Suitable for compressed air and other fluids in various fields

Max. Working Pressure	Material	Medium	Norm
PN 16 / 25 bar	steel	compressed air a.o.	☉ below

Hose Menders DIN 20038 without safety collar

Hose i.D.	DN	h	b	Weight/pc. g	☉	Type No.
3/8" = 10 mm	8	75	11	25	10	SV 10 R
1/2" = 13 mm	9	80	13.5	44	10	SV 13 R
5/8" = 15 mm	12.5	105	17	73	10	SV 15 R
3/4" = 19 mm	16	105	21	93	10	SV 19 R
1" = 25 mm	22	160	26.5	166	10	SV 25 R
1 1/4" = 32 mm	27	175	33.5	351	5	SV 32 R
1 1/2" = 38 mm	33	215	40	430	5	SV 38 R
2" = 50 mm	45	225	51	670	1	SV 50 R
2" = 53 mm	46	225	54	960	1	SV 53 R

For hose clamps DIN 20039 A, type SL (☉ catalogue page 47)



Hose Menders DIN 20038 with safety collar

Hose i.D.	DN	h	b	☉Safety collar	Weight/pc. g	☉	Type No.
1/2" = 13 mm	9	80	13.5	25	48	10	SV 13 R/S
5/8" = 15 mm	12.5	105	17	30	77	10	SV 15 R/S
3/4" = 19 mm	16	105	21	34	107	10	SV 19 R/S
1" = 25 mm	22	160	26.5	42	170	10	SV 25 R/S
1 1/4" = 32 mm	27	175	33.5	50	382	5	SV 32 R/S
1 1/2" = 38 mm	33	215	40	56	490	5	SV 38 R/S
2" = 50 mm	45	225	51	78	870	1	SV 50 R/S
2" = 53 mm	46	225	54	78	1126	1	SV 53 R/S
3" = 75 mm	68	250	76	110	1811	1	SV 75 R/S

For hose clamps DIN 20039 B, type SK (☉ catalogue page 47)



Male thread nipples with thread ferrule (according to DIN EN 14424)

For Hose	Thread	DN	h	Stem		Thread		Weight/pc. g	☉	Type No.
				Hexagon	Length	Length	Thread			
1/2" = 13 x 3	G 1/2"	11	50	22	27	12	12	102	10	G 12-133 TQ
1/2" = 13 x 5	G 1/2"	11	50	22	27	12	12	104	10	G 12-135 TQ
5/8" = 15 x 5	G 3/4"	13	52	27	30	13	13	140	10	G 34-155 TQ
3/4" = 19 x 5	G 3/4"	17	52	27	30	13	13	170	10	G 34-195 TQ
3/4" = 19 x 6	G 3/4"	17	52	27	30	13	13	180	10	G 34-196 TQ
1" = 25 x 5	G 1"	22	58	36	36	14	14	220	10	G 10-255 TQ
1" = 25 x 7	G 1"	22	58	36	36	14	14	230	10	G 10-257 TQ

Assembly instructions for thread ferrules (☉ catalogue page 182)

Other sizes on request



New!